

INSTALLATION INSTRUCTIONS FOR HOCHIKI ANALOGUE SMOKE SENSORS TYPE:ALK

INTRODUCTION

Analogue Smoke Sensor	ALK-ASN
Analogue Sensor Base	YBN-R/3

Other combinations of sensor and base are also possible.
Please confirm with Hochiki or the appointed sales agent.

Ensure that the following items are observed before installation and maintenance. Hochiki cannot warrant a sensor's performance if such items are neglected.

CAUTION

- This sensor cannot be used to prevent FIRE itself, it is only intended to detect a certain characteristic of fire.
- When installing this sensor, ensure that the location of each sensor has been planned in accordance with appropriate local and National fire regulations or recommendations.
- The detector shall not be installed in the following environmental conditions:
 - Situations in which condensation exists.
 - Situations in which corrosive gases exist.
 - Situations in which dust or steam exist.
 - Situations in which obstacles exist, which could impede airflow to the detector.
- Certain actions can cause permanent damage to the sensor and therefore if the sensor is subjected to any of the following actions it should not be used:
 - Disassembly and reassembly.
 - Impact or shock.
- The sensor should therefore be replaced after a fire has occurred if damage is suspected.
- After installation, all sensors on the fire alarm system should be tested to verify correct operation.
- Installation and maintenance should only be carried out by suitably trained personnel.
- The sensor must be subject to periodic maintenance during regular service visits, which should be as recommended by appropriate local and National Standards or recommendations. In the event of no such Standards existing, Hochiki recommend that the minimum period of maintenance should be 1 year and that the following items should be taken into account:
 - A regular operational test should be performed.
 - A visual check for staining and mechanical damage should be made.
- Sensor operation should not be verified by the use of a naked flame or open fire. Operation should only be checked by equipment that is capable of exceeding the required detection threshold by a small amount sufficient to guarantee a fire signal is produced by the sensor.
- A dust cover is included on the sensor to ensure that contamination cannot affect the correct operation of the sensor. The dust cover must be removed for the sensor to operate.
- The correct operation and function of each sensor must be checked during installation. Regular checks of each device's operation should be made to ensure that the system continues to operate correctly.
- Any setting outside the range 2 to 4.5% has not been verified for conformance AS7240.7.

EXTERNAL VIEW

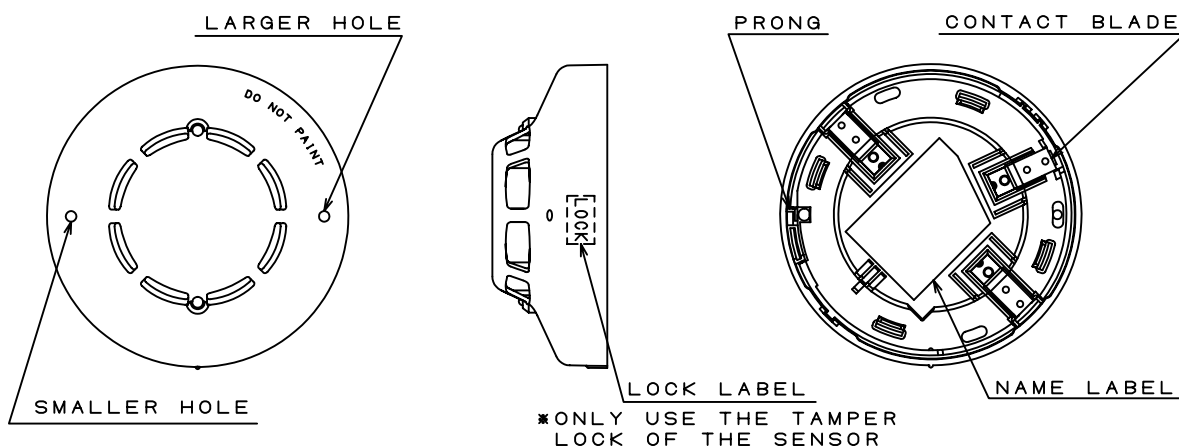

Fig. 1

SETTING THE ADDRESS

- Each sensor must have its address set before system operation.
- Using the installation plan which shows the proper location for each sensor, find the address for the sensor to be installed. Ensure that the address and location on the plan match correctly.
- Address is set to 127, when shipping from a factory.
- For address setting, use the address programmer and write the number on the label of the sensor after setting.
- When address changing, renew the number on the label.
- See the instruction manual of the Hand Held Programmer (TCH-A200 or TCH-B100) about detail of setting method.

WIRING

The wiring diagram for the analogue sensor base should be made as shown in Fig. 2.

[STANDARD CONFIGURATIONS]

A: Communication Line
Positive (+) S
B: Power Line
Positive (+)
C: Communication Line
Negative (-) SC

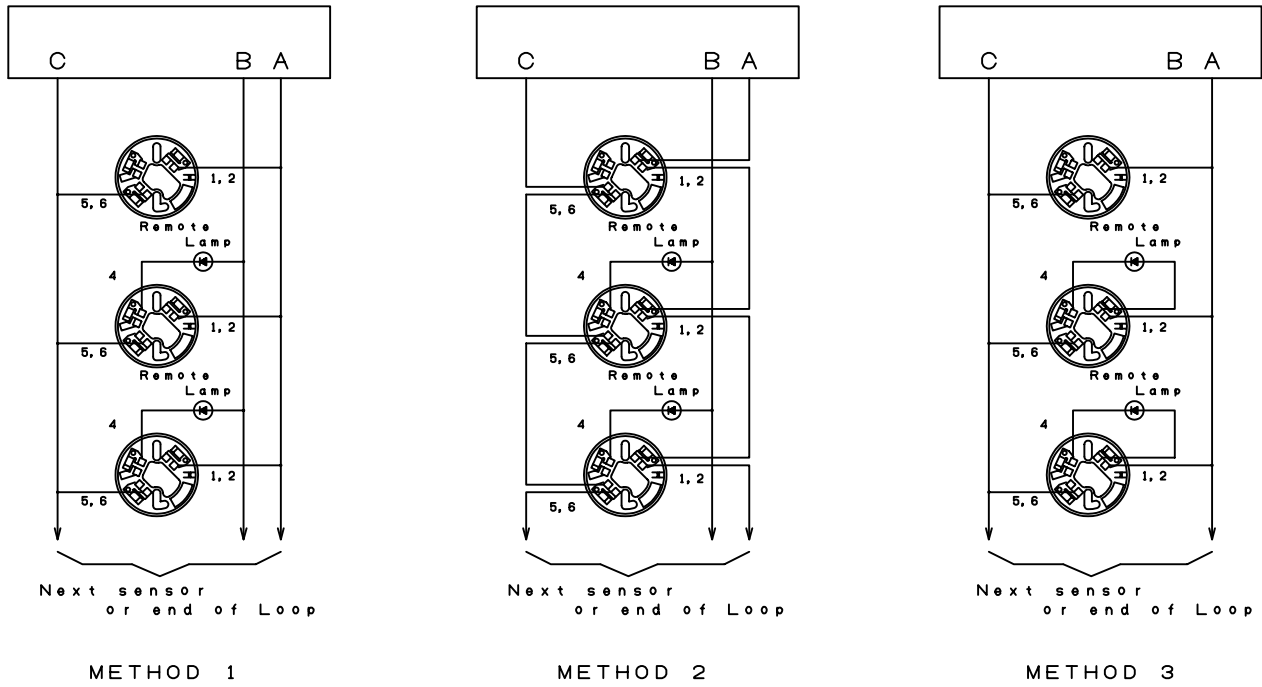

Fig. 2

HOW TO USE THE SENSOR HEAD REMOVER

- 1) In case of sensor head mounting to the base.
 - a) Fit and insert the 2 push rods of the remover to the holes on the sensor.
 - b) Softly push the remover which mounts the sensor to the sensor base and twist clockwise for secure fitting of the sensor head and base.
- 2) In case of sensor removal from the base.
 - a) Fit and insert the 2 push rods of the remover to the holes on the sensor.
 - b) Twist counterclockwise for removal of the sensor head from the base.

HOW TO USE THE TAMPER LOCK OF THE SENSOR

- 1) Remove prong located back side of the sensor and put the LOCK label to the side of the sensor. (The label is packed together with the sensor)
- 2) Mount the sensor to the base bringing seams of the sensor and base into line for secure tamper locking.
- 3) Tamper locked sensor can be removed from the base by the sensor remover which has a mechanism to release the tamper lock.

HOW TO REMOVE THE TAMPER LOCKED SENSOR

- 1) Fit and insert the larger and smaller push rods of the remover for tamper lock releasing to the holes on the sensor. Larger hole is located by the indication of "DO NOT PAINT" on the sensor.
- 2) Push the remover toward sensor for release the tamper lock and twist counterclockwise for removal of the sensor head from the base.

