

Instruction Insert: Vantage Combi Spatial 32-Tone Sounder / Beacon

Part Numbers Description

511-xxx Series 24v 32 Tone Vantage Combi Sounder / Beacon

Voltage Range

18 - 35v

Units available with Deep or Shallow base. Lens colour options available - red, amber, blue, clear.
Please contact our sales office for full list of part numbers.

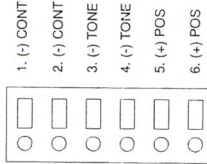
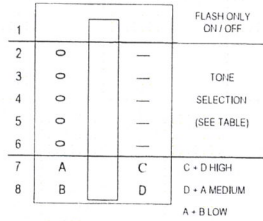

For tone wire neg to term 3 and/or 4
For 2nd tone wire neg to 1 and/or 2
Note that the 2nd tone will over-ride tone

All Vantage sounders are delivered with the volume set to medium and tone set to 11111 (Cranford sweep)

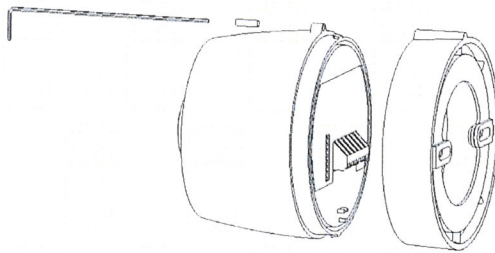

Shallow Base - IP43

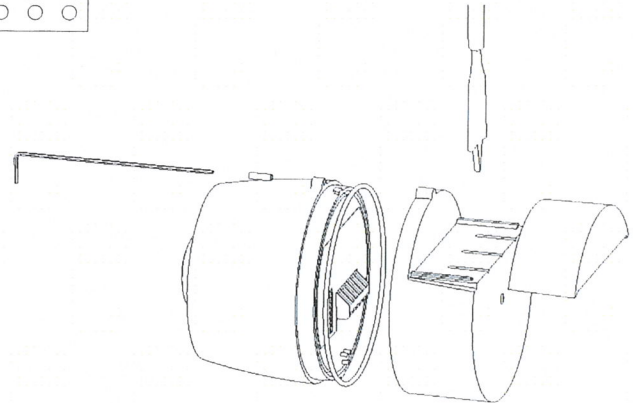

Deep Base - IP65

Allen Key not supplied
Available separately - part no. 117-060 (pack of 5)

Full datasheet available - DS040

www.cranfordcontrols.com



RoHS
Compliant

Doc No: 125-025 Issue No: 003

MADE IN UK

No.	Tone	Description	Switch 23456	Second Stage Alarm	Typical Current (mA) Tone			Typical Sound Output (dBa) Tone		
					L	M	H	L	M	H
1	LF Sweep (Cranford sweep)	800-1000 Hz	11111	800 Hz cont	7	12	18	86	101	106
2	Alternative warble	800/960 Hz at 2 Hz	11110	800 Hz cont	7	12	17	86	100	105
3	Warble Tone	800/1000 Hz @ 0.5 sec	11101	800 Hz cont	7	12	18	87	101	106
4	Alternative warble	500/600 Hz @ 2 Hz	11100	500 Hz cont	6	10	13	84	99	102
5	HF Back up Interrupted tone	2800 Hz @ 1.0 sec on/off	11011	2800 Hz cont	8	17	35	93	106	114
6	LF Back up Alarm	800 Hz @ 150 msec on/off	11010	800 Hz cont	6	9	12	80	95	99
7	HF Back up Interrupted tone - fast	2800 Hz @ 150 msec on/off	11001	800 Hz cont	7	16	35	92	105	113
8	LF Continuous tone BS5839	800 Hz cont	11000	Same tone	7	11	16	82	96	100
9	Sweep tone (1 Hz)	800/900 Hz @ 1Hz	10111	800 Hz cont	7	12	19	87	101	106
10	Australian slow whoop	Intermittent 970 Hz 0.625 ms on/0.625 ms off	10110	500-1200 Hz 3.75 sec on 0.25 sec off	7	12	18	87	101	106
11	Dutch sweep tone	970 Hz cont	10101	500-1200 Hz 3.5 sec on 0.5 sec off	7	12	18	87	101	106
12	Analogue sweep tone	500/600 Hz @ 2 Hz	10100	500 Hz cont	6	10	13	84	99	102
13	Sweep tone (3 Hz)	800/970 Hz @ 3 Hz	10011	800 Hz cont	7	12	17	85	100	105
14	Alternate HF slow sweep	2350/2900 Hz @ 3 Hz	10010	2400 Hz cont	8	16	32	92	106	113
15	Fast HF sweep	2400-2800 Hz @ 7 Hz	10001	2400 Hz cont	8	16	32	92	105	112
16	US Temporal Pattern LF	950 Hz for 0.5 sec on 0.5 sec off x 3 then 1.5 sec then repeat	10000	800 Hz cont	6	11	13	86	100	104
17	Interrupted tone	Interrupted tone 800 Hz @ 0.5 sec on/off	01111	800 Hz cont	6	9	12	81	96	100
18	ISO 8201 LF BS5839 Pt 1 1988	Intermittent 970 Hz 500 ms on / 500 ms off	01110	Same tone	6	11	13	87	101	106
19	Interrupted tone medium	1000 Hz @ 0.25 sec on / off	01101	800 Hz cont	6	9	12	86	101	105
20	ISO8201 HF	Intermittent 2850 Hz 500 ms on / 500 ms off	01100	Same tone	7	16	35	92	105	113
21	Continuous tone	1000 Hz continuous	01011	Same tone	7	12	19	87	101	106
22	LF Buzz	800-950 Hz swept at 110 Hz	01010	800 Hz cont	7	12	17	86	100	105
23	HF Continuous	2800 Hz	01001	2800 Hz cont	8	17	35	93	106	114
24	Sweep tone (9 Hz)	800-970 Hz @ 9 Hz	01000	800 Hz cont	7	12	17	86	101	105
25	German DIN tone	Sweep 1200-500 Hz @ 1 Hz	00111	800 Hz cont	7	11	17	85	100	104
26	Swedish Fire signal	Intermittent 660 Hz 150 ms on / 150 ms off	00110	Same tone	6	8	11	82	97	101
27	French tone AFNOR	554 Hz for 100 ms and 440 Hz for 400 ms	00101	800 Hz cont	6	9	12	83	99	102
28	Swedish all clear signal	Continuous 660 Hz	00100	Same tone	6	10	15	83	98	102
29	US Temporal Pattern HF	2900 Hz for 0.5 sec on 0.5 off x 3 then off for 1.5 sec then repeat	00011	2900 Hz cont	8	12	31	92	105	113
30	Siren 2 way ramp (short)	500/1200 Hz rising then falling 0.25 sec	00010	800 Hz cont	7	11	15	85	99	103
31	FP1063.1-Telecom	Alternating tone 800/970 Hz @ 2 Hz	00001	800 Hz cont	7	12	17	86	101	105
32	Siren 2 way ramp (long)	500/1200 Hz 3 sec rising / 3 sec falling	00000	800 Hz cont	7	12	19	87	101	105
	Continuous tone	500 Hz Continuous	-	-	6	9	12	84	100	103
	Dutch Tone (Override tone)	500-1200 Hz 3.5 sec on and 0.5 sec off	-	-	7	11	18	86	101	105
	Australian Slow Whoop Override Tone	Sweep 500-1200 Hz 3.75 sec on	-	-	7	11	19	87	101	105
	Continuous Tone	2400 Hz Continuous	-	-	8	15	28	86	98	105
	Continuous Tone	2900 Hz Continuous	-	-	8	16	33	92	106	113